

SPECIFICATION FOR APPROVAL

承 认 书

Customer : _____
Description : **Ultrasonic sensor**
Vender's Part No. : **KS-A1640H10.5S**
Customer No. : _____
Date : **2014-4-19**

CUSTOMER'S APPROVED SIGNATURE

CUSTOMER'S APPROVED SIGNATURE		



DONGGUAN COSSON ELECTRONIC PLASTIC CO., LTD

东莞市科森电子塑胶有限公司



ADD: Industry Shangsha, ChangAnTown, DongGuan Yin City, GuangDong, China.

Tel:+86-769-81885857 Fax:+86-769-81885897

Approved By	Checked By	Made By
colin	Chen JO	Alice

A、SCOPE 范围

This specification applies ultrasonic sensor diaphragm, KS-A1640H10.5S

此规格适用于超声波传感器, KS-A1640H10.5S

B、SPECIFICATION 规格

No.	Item	Unit	Specification	
1	中心频率 Fo Center Frequency	KHz	40±1	
2	自由电容 Free Capacitance	pF	2000±20%	
3	声压 Min. Sound Pressure level	dB	≥100	
4	灵敏度 Sensitivity	dB	≥-75dB	
5	材料 Material		Aluminum	
6	Operating temp 操作温度	°C	-40°C ~ +85°C	
7	Storage temp 储存温度	°C	-40°C ~ +85°C	
8	Dimension 尺寸	mm	16*10.5	
9	Weight	g	1.0	



C、APPEARANCE DRAWING 外观尺寸图

Model NO : KS-A1640H10.5S

Unit:mm TOL: ± 0.5

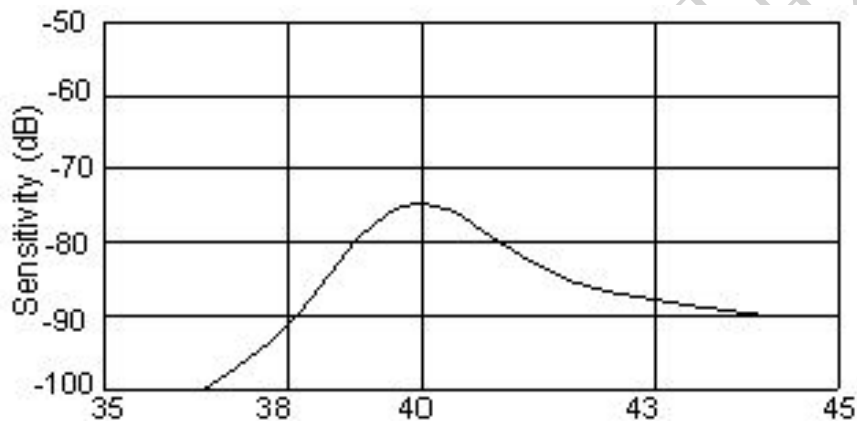
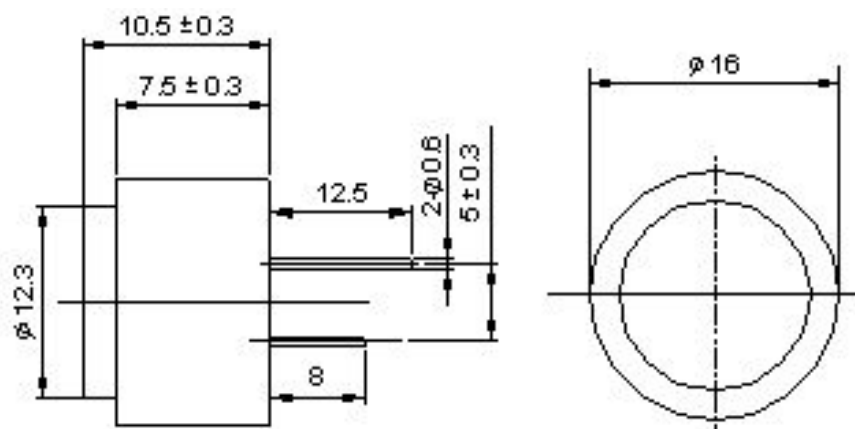

D、DIRECTIVITY 方向特性

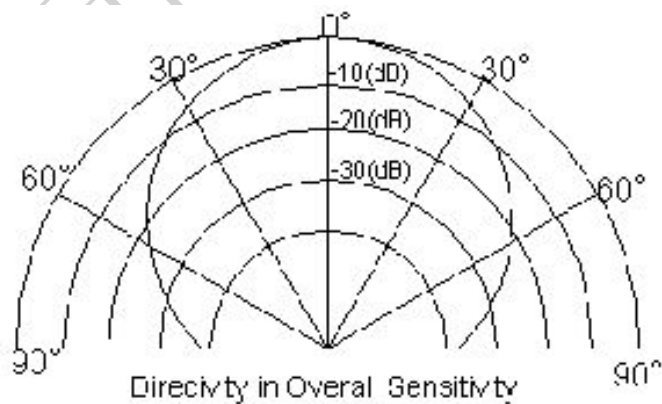

E、TEST CIRCUIT 测试线路推荐

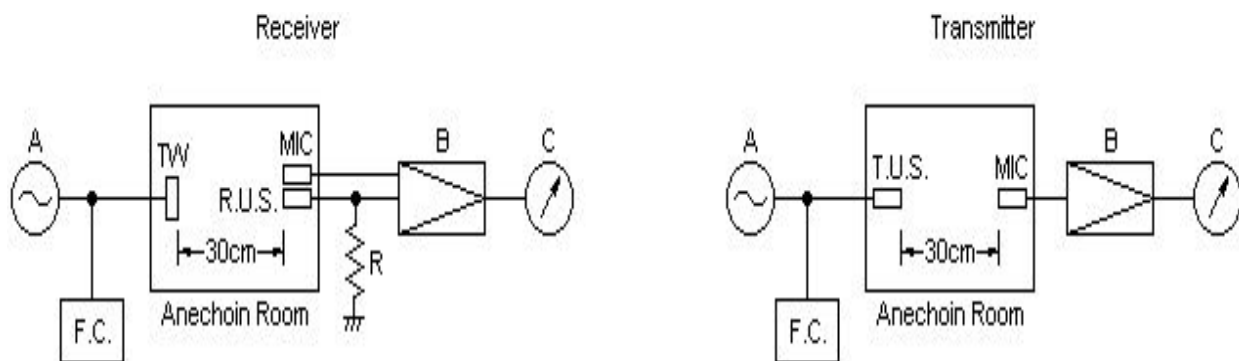

A: Oscillator B: Amplifier C: Voltmeter R: 3.9K MIC: Microphone TW: Tweeter R.U.S.: Receiver Ultrasonic Sensor T.U.S.: Transmitter Ultrasonic Sensor F.C.: Frequency Counter

※ NOTES

- ⌘ This sensor is designed for use in air. Do not use this sensor in fluid.
- ⌘ To prevent sensor malfunctions, operational failure or any deterioration of its characteristics, do not use this sensor in the following, or similar conditions.
 - A. In strong shock or vibration.
 - B. In high temperature and humidity for a long time. C. In corrosive gases or sea breeze.
 - D. In an atmosphere of organic solvents.
- In dirty and dusty environments that may contaminate the sensor front.

